

ALFA K20T
1000 p.s.i. | PN 63

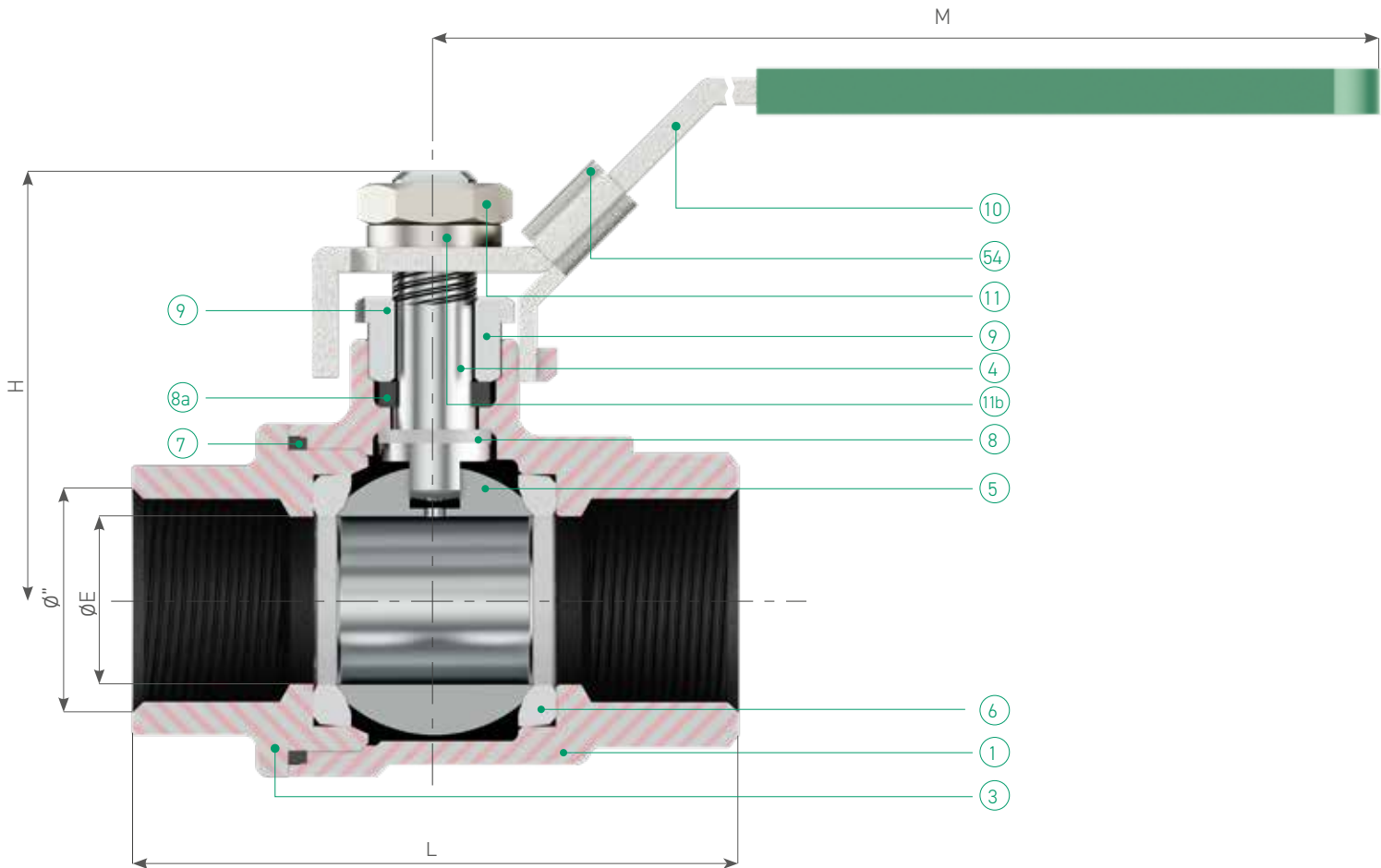

ALFA K20T

1000 p.s.i. | PN 63

Standard valve materials / Kugelhahn Standardwerkstoffe

	PART NAME	Q.TY	MATERIALS	
	BEZEICHNUNG		STK	WERKSTOFFE
1	body Gehäuse	1	ASTM A216 WCB	ASTM A351 CF8M
3	closure Verschluss	1	ASTM A216 WCB	ASTM A351 CF8M
4	stem Schaltwelle	1	AISI 316	
5	ball Kugel	1	ASTM A351 CF8M	
6	seats Sitzring	2	P.T.F.E.	
7	body gasket Gehäusedichtung	1	P.T.F.E.	
8	washer Dichtscheibe	1	P.T.F.E.	
8a	stem packing Schaltwellendichtung	1	GRAPHOIL	
9	gland Druckring	1	AISI 304	
10	lever Handhebel	1	AISI 304	
11	stem nut Schaltwellenmutter	1	AISI 304	
11b	thrust washer Anlaufscheibe	1	AISI 304	
54	locking device Verriegelung	1	AISI 304	

DIMENSIONS / ABMESSUNGEN

DN	06	10	15	20	25	32	40	50
ø"	¼"	¾"	½"	¾"	1	1¼"	1½"	2"
ø E	10,6	12	15	20	25	32	38	50
L	56	56	60	72,4	85	94	105	125
M	100	100	100	129	156	156	182,5	182,5
H	58	58	58	64	77	83	96	102
Kg.	0,25	0,25	0,35	0,55	0,99	1,30	2,2	3,3

(P,T) DIAGRAMS / DIAGRAMM

